

SIGN	DATE	DESCRIPTION	APPROVER
△			
△			
△			

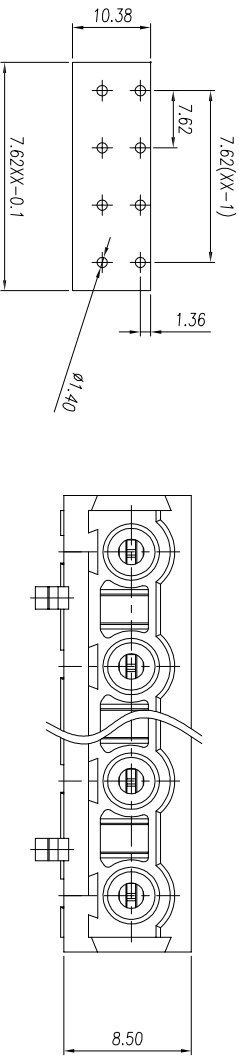

**P.C.B. LAYOUT**

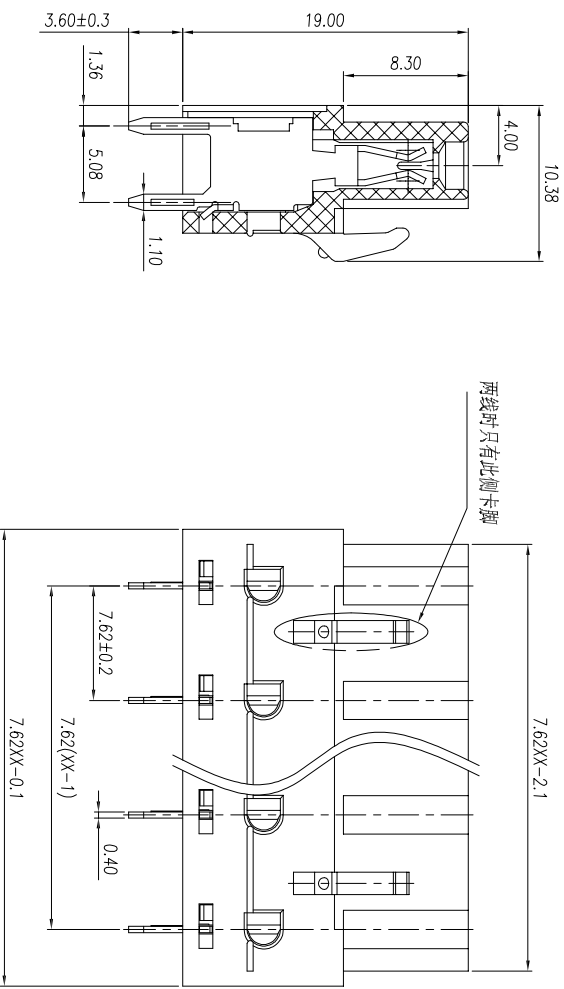

材质: 电镀/ Material  
 绝缘件/ Insulator body: PA66, UL94V-0  
 夹子/ Clamp: Copper alloy, Sn plated

电器性能/ Electrical  
 参考标准/ Standard: UL IEC  
 额定电压/ Rated voltage: 300V 400V  
 额定电流/ Rated current: 1.5A 13.5A  
 接触电阻/ Contact resistance: 20mΩ (max)  
 绝缘电阻/ Insulation resistance: 500MΩ / 500V  
 耐电压/ Withstanding voltage: AC 2000V/1Min

机械性能/ Mechanical  
 温度范围/ Temperature range: -40°C to +120°C  
 瞬间温度/ Max soldering: +250°C, for 5 Sec

尺寸/ Dimensions  
 间距/ Pitch: 7.62mm  
 极数/ Poles: 2-24P

N=Number of contacts

**慈溪万海电子有限公司**  
**CIXI WANHAI ELECTRONICS CO., LTD.**

PART NAME: 2EDGB-7.62-XXP		TITLE:	
PART NO.:		DWG NAME:	
APPROVED BY	CHECKED BY	DESIGNED BY	DRAWN BY
CUSTOM NO.:		UNIT: 5mm	
		SCALE: 1/1	
		REVISION: B1	
		Tolerance	
		X ±0.50	
		X.X ±0.30	
		X.XX ±0.10	
		X° ±1°	

