

1

2

3

4

5

6

7

SIGN	DATE	DESCRIPTION	APPROVER
▲			
▲			
▲			

E

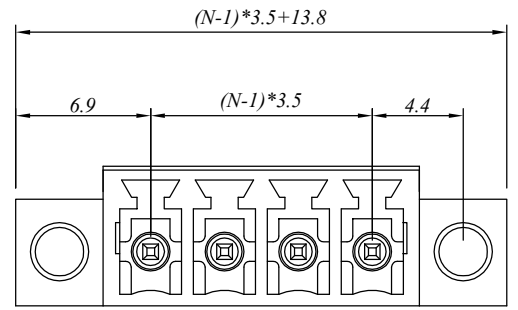

### P.C.B. LAYOUT

#### 材质于电镀 / Material

塑件/Insulator body: PA66, UL94V-0  
 焊针/Pin header: Brass, Tin planted

#### 电器性能 / Electrical

参考标准/Standard: UL IEC  
 额定电压/Rated voltage: 300V 250V  
 额定电流/Rated current: 8A 10A  
 接触电阻/Contact resistance: 20m Ω (max)  
 绝缘电阻/Insulation resistance: 500M Ω /500V  
 耐电压/Withstanding voltage: AC 2000V/1Min

#### 机械性能 / Mechanical

温度范围/Temperature range: -40°C to +105°C  
 瞬间温度/Max soldering: +250°C, for 5 Sec

#### 尺寸 / Dimensions

间距/Pitch: 3.5mm  
 极数/Poles: 2-24P

D

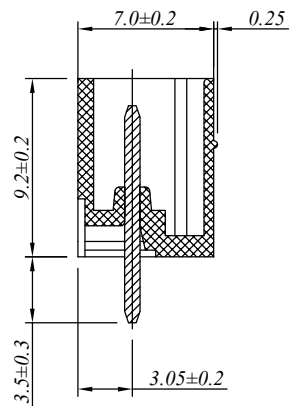
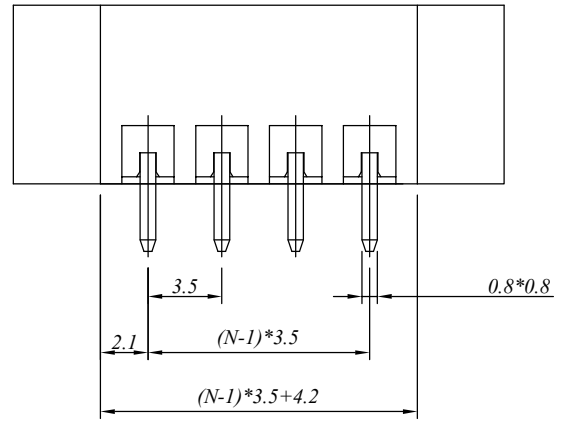

C

N= Number of concats

B

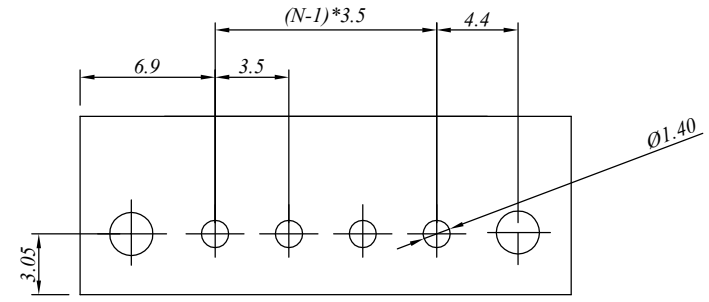

A

## 慈溪万海电子有限公司 CIXI WANHAI ELECTRONICS CO., LTD.

PART NAME: 15EDGVM-3.50-XXP				TITLE:	
PART NO.:				DWG NAME:	
APPROVED BY	CHECKED BY	DESIGNED BY	DRAWN BY	CUSTOM NO.:	Tolerance X ±0.50 X.X ±0.30 X.XX ±0.10 X° ±1°
				UNITS: mm	
				SCALE: 4/1	
				REVISION: 1	

1 2 3 4 5 6 7

SIGN	DATE	DESCRIPTION	APPROVER
△			
△			
△			

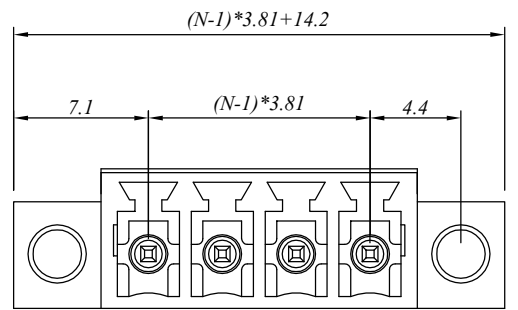

## P.C.B. LAYOUT

### 材质于电镀 / Material

塑件 / Insulator body: PA66, UL94V-0  
 焊针 / Pin header: Brass, Tin plated

### 电器性能 / Electrical

参考标准 / Standard: UL IEC  
 额定电压 / Rated voltage: 300V 250V  
 额定电流 / Rated current: 8A 10A  
 接触电阻 / Contact resistance: 20mΩ (max)  
 绝缘电阻 / Insulation resistance: 500MΩ / 500V  
 耐电压 / Withstanding voltage: AC 2000V / 1Min

### 机械性能 / Mechanical

温度范围 / Temperature range: -40°C to +105°C  
 瞬间温度 / Max soldering: +250°C, for 5 Sec

### 尺寸 / Dimensions

间距 / Pitch: 3.81mm  
 极数 / Poles: 2-24P

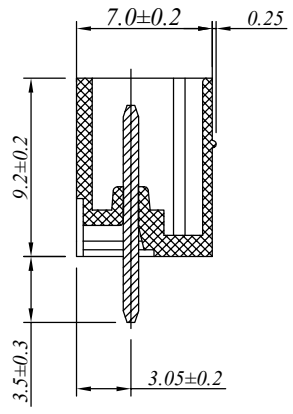
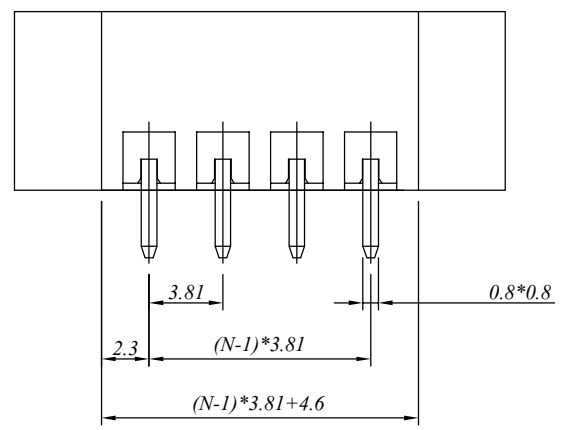

N = Number of concats

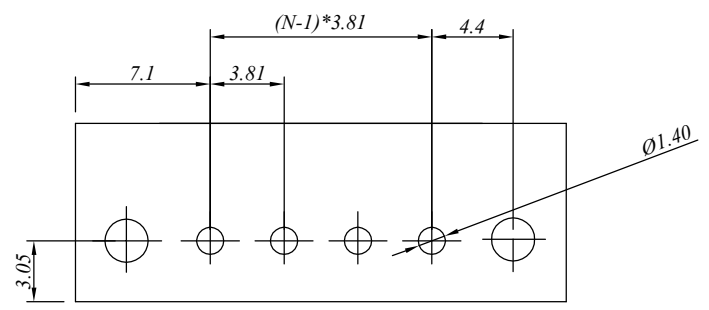

## 慈溪万海电子有限公司 CIXI WANHAI ELECTRONICS CO., LTD.

PART NAME: 15EDGVM-3.81-XXP				TITLE:	
PART NO.:				DWG NAME:	
APPROVED BY	CHECKED BY	DESIGNED BY	DRAWN BY	CUSTOM NO.:	Tolerance X ±0.50 X.X ±0.30 X.XX ±0.10 X° ±1°
				UNITS: mm	
				SCALE: 4/1	
				REVISION: 1	