

1

2

3

4

5

6

7

|   |  |  |  |
|---|--|--|--|
| △ |  |  |  |
| △ |  |  |  |
| △ |  |  |  |

E

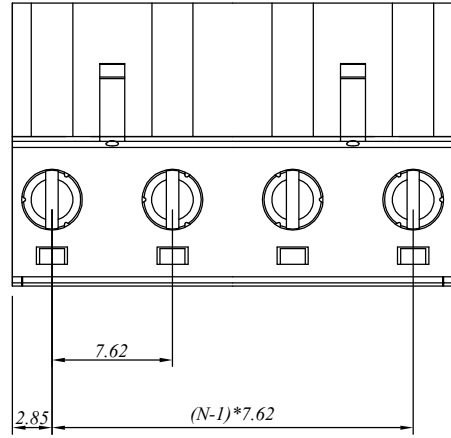

D

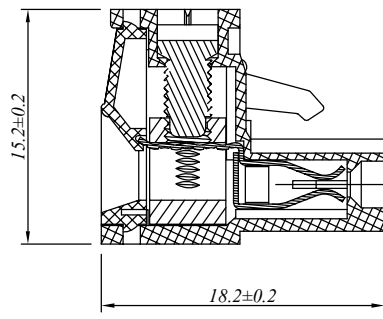

C

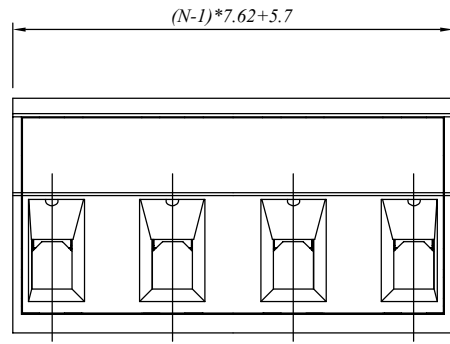

B

材质于电镀/ Material

塑件/Insulator body: PA66, UL94V-0  
 方块/Contact(metal housing): Brass ,Ni plated  
 螺丝/Terminal screw: M3.0, Steel Zn plated  
 夹子/Clamp: Phosphor bronze, Ni plated

电器性能/ Electrical

参考标准/Standard: UL IEC  
 额定电压/Rated voltage: 300V 450V  
 额定电流/Rated current: 15A 20A  
 接触电阻/Contact resistance: 20mΩ (max)  
 绝缘电阻/Insulation resistance: 500MΩ /500V  
 耐电压/Withstanding voltage: AC 2000V/1Min  
 使用线径/Wire range: 14-28AWG, 2.5mm<sup>2</sup>

机械性能/ Mechanical

扭矩/Torque: 0.5Nm(4.5Lb.in)  
 温度范围/Temperature range: -40°C to +105°C  
 剥线长度/Steip length: 7-8mm  
 瞬间温度/Max soldering: +250°C, for 5 Sec

尺寸/Dimensions

间距/Pitch: 7.62mm  
 极数/Poles: 2-24P

A

N=Number of contacts

慈溪万海电子有限公司  
**CIXI WANHAI ELECTRONICS CO., LTD.**

|                            |            |             |          |             |  |
|----------------------------|------------|-------------|----------|-------------|--|
| PART. NAME: 2EDGK-7.62-XXP |            |             |          | TITLE:      |  |
| PART. NO.:                 |            |             |          | DWG NAME:   |  |
| APPROVED BY                | CHECKED BY | DESIGNED BY | DRAWN BY | CUSTOM NO.: | Tolerance<br>X ±0.50<br>X.X ±0.30<br>X.XX ±0.10<br>XX° ±1° |
|                            |            |             |          | UNITS:mm    |  |
|                            |            |             |          | SCALE3/1    |  |
|                            |            |             |          | REVISIONB3  |  |