

1

2

3

4

5

6

7

SIGN	DATE	DESCRIPTION	APPROVER
△			
△			
△			

E

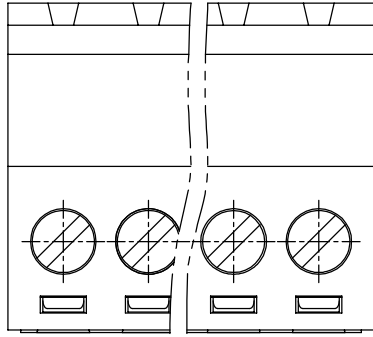

D

材质于电镀/Material

塑件/Insulator body: PA66, UL94V-0
 方块/Contact(metal housing): Brass ,Ni plated
 螺丝/Terminal screw: M3.0, Steel Zn plated
 夹子/Clamp: Phosphor bronze, Ni plated

电器性能/Electrical

参考标准/Standard: UL IEC
 额定电压/Rated voltage: 300V 450V
 额定电流/Rated current: 15A 20A
 接触电阻/Contact resistance: 20mΩ (max)
 绝缘电阻/Insulation resistance: 500MΩ /500V
 耐电压/Withstanding voltage: AC 2000V/1Min
 使用线径/Wire range: 14-28AWG, 2.5mm²

C

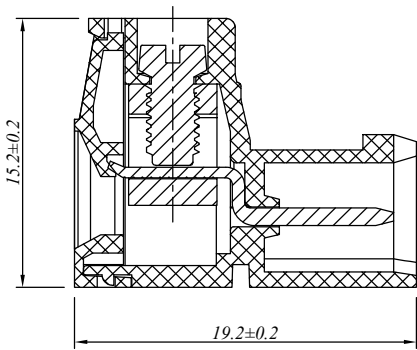
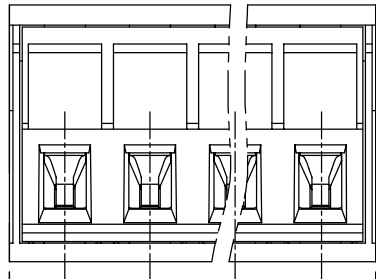

机械性能/Mechanical

扭矩/Torque: 0.5Nm(4.5Lb.in)
 温度范围/Temperature range: -40°C to +105°C
 剥线长度/Steip length: 7-8mm
 瞬间温度/Max soldering: +250°C, for 5 Sec

B

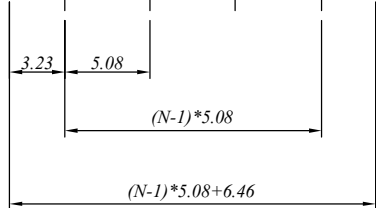

尺寸/Dimensions

间距/Pitch: 5.08mm
 极数/Poles: 2-24P

A

N=Number of contacts

慈溪万海电子有限公司
CIXI WANHAI ELECTRONICS CO., LTD.

PART. NAME: 2EDGKR-5.08-XXP				TITLE:	
PART. NO.:				DWG NAME:	
APPROVED BY	CHECKED BY	DESIGNED BY	DRAWN BY	CUSTOM NO.:	Tolerance X ±0.50 X.X ±0.30 X.XX ±0.10 XX° ±1°
				UNITS:mm	
				SCALE:1.9/1 REVISION:5	