

1

2

3

4

5

6

7

SIGN	DATE	DESCRIPTION	APPROVER
△			
△			
△			

E

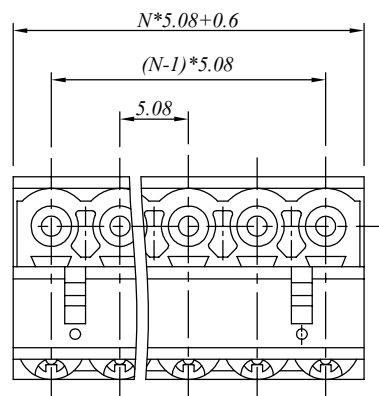

D

### 材质于电镀/ Material

塑件/Insulator body:

PA66, UL94V-0

弹片/Shrapnel:

Stainless steel

夹子/Clamp:

Phosphor bronze, Ni planted

### 电器性能/ Electrical

参考标准/Standard:

UL IEC

额定电压/Rated voltage:

300V 450V

额定电流/Rated current:

10A 20A

接触电阻/Contact resistance:

20m Ω (max)

绝缘电阻/Insulation resistance:

500M Ω /500V

耐电压/Withstanding voltage:

AC 2000V/1Min

使用线径/Wire range:

14-28AWG, 2.5mm<sup>2</sup>

C

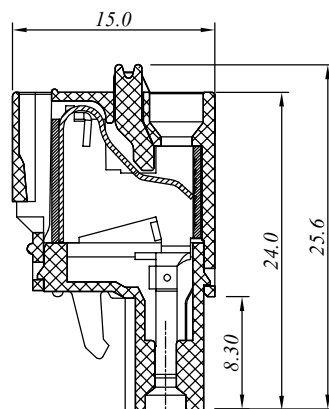
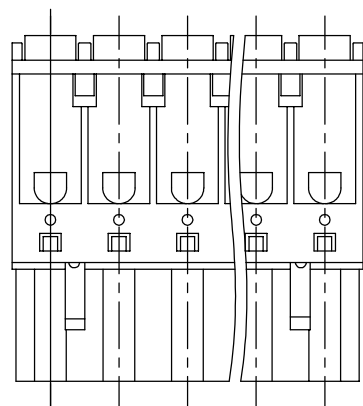

### 机械性能/ Mechanical

温度范围/Temperature range:

-40°C to +105°C

剥线长度/Steip length:

7-8mm

### 尺寸/Dimensions

间距/Pitch:

5.08mm

极数/Poles:

2-24P

B

N=Number of contacts

A

慈溪万海电子有限公司  
CIXI WANHAI ELECTRONICS CO., LTD.

PART. NAME: 2EDGKD-5.08-XXP				TITLE:	
PART. NO.:				DWG NAME:	
APPROVED BY	CHECKED BY	DESIGNED BY	DRAWN BY	CUSTOM NO.:	Tolerance
					X ±0.50
					X.X ±0.30
					X.XX ±0.10
					XX° ±1°
				UNITS:mm	
				SCALE:1.9/1	
				REVISION:5	