

1

2

3

4

5

6

7

SIGN	DATE	DESCRIPTION	APPROVER
△			
△			
△			

E

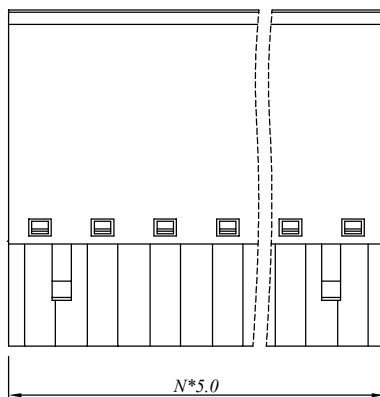

D

#### 材质于电镀/Material

塑件/Insulator body:	PA66, UL94V-0
方块/Contact(metal housing):	Brass ,Ni plated
螺丝/Terminal screw:	M2.5, Steel Zn plated
夹子/Clamp:	Phosphor bronze, Ni plated
滑块/Slide block	Steel Zn plated

#### 电器性能/Electrical

参考标准/Standard:	UL	IEC
额定电压/Rated voltage:	300V	450V
额定电流/Rated current:	15A	17.5A
接触电阻/Contact resistance:	20mΩ (max)	
绝缘电阻/Insulation resistance:	500MΩ /500V	
耐电压/Withstanding voltage:	AC 2000V/1Min	
使用线径/Wire range:	14-28AWG, 1.5mm <sup>2</sup>	

C

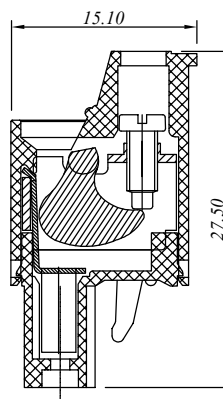

#### 机械性能/Mechanical

扭矩/Torque:	0.4Nm(3.6Lb.in)
温度范围/Temperature range:	-40°C to +105°C
剥线长度/Steip length:	7-8mm
瞬间温度/Max soldering:	+250°C, for 5 Sec

B

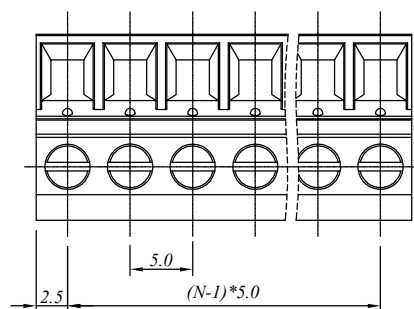

#### 尺寸/Dimenions

间距/Pitch:	5.0mm
极数/Poles:	2-24P

A

$N$ =Number of contacts

## 慈溪万海电子有限公司 CIXI WANHAI ELECTRONICS CO., LTD.

PART. NAME: 2EDGKC-5.0-XXP

TITLE:

PART. NO.:

DWG NAME:

APPROVED BY

CHECKED BY

DESIGNED BY

DRAWN BY

CUSTOM NO.:

Tolerance

X ±0.50

X.X ±0.30

X.XX ±0.10

XX° ±1°



UNITS:mm

SCALE:1.9/1

REVISION:5

1

2

3

4

5

6

7

SIGN	DATE	DESCRIPTION	APPROVER
△			
△			
△			

E

$N * 5.08$

D

材质于电镀/*Material*

塑件/ <i>Insulator body</i> :	PA66, UL94V-0
方块/ <i>Contact(metal housing)</i> :	Brass ,Ni plated
螺丝/ <i>Terminal screw</i> :	M2.5, Steel Zn plated
夹子/ <i>Clamp</i> :	Phosphor bronze, Ni plated
滑块/ <i>Slide block</i> :	Steel Zn plated

电器性能/*Electrical*

参考标准/ <i>Standard</i> :	UL	IEC
额定电压/ <i>Rated voltage</i> :	300V	450V
额定电流/ <i>Rated current</i> :	15A	17.5A
接触电阻/ <i>Contact resistance</i> :	20mΩ (max)	
绝缘电阻/ <i>Insulation resistance</i> :	500MΩ /500V	
耐电压/ <i>Withstanding voltage</i> :	AC 2000V/1Min	
使用线径/ <i>Wire range</i> :	14-28AWG, 1.5mm <sup>2</sup>	

C

机械性能/*Mechanical*

扭矩/ <i>Torque</i> :	0.4Nm(3.6Lb.in)
温度范围/ <i>Temperature range</i> :	-40°C to +105°C
剥线长度/ <i>Steip length</i> :	7-8mm
瞬间温度/ <i>Max soldering</i> :	+250°C, for 5 Sec

B

$2.54$        $5.08$        $(N-1) * 5.08$

尺寸/*Dimenstions*

间距/ <i>Pitch</i> :	5.0mm
极数/ <i>Poles</i> :	2-24P

A

*N=Number of contacts*

慈溪万海电子有限公司  
**CIXI WANHAI ELECTRONICS CO., LTD.**

PART. NAME: 2EDGKC-5.08-XXP

TITLE:

PART. NO.:

DWG NAME:

APPROVED BY

CHECKED BY

DESIGNED BY

DRAWN BY

CUSTOM NO.:

Tolerance

X ±0.50

X.X ±0.30

X.XX ±0.10

XX° ±1°

UNITS:mm

SCALE:1.9/1

REVISION:5