

1

2

3

4

5

6

7

SIGN	DATE	DESCRIPTION	APPROVER
△			
△			
△			

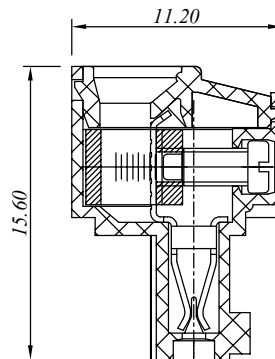
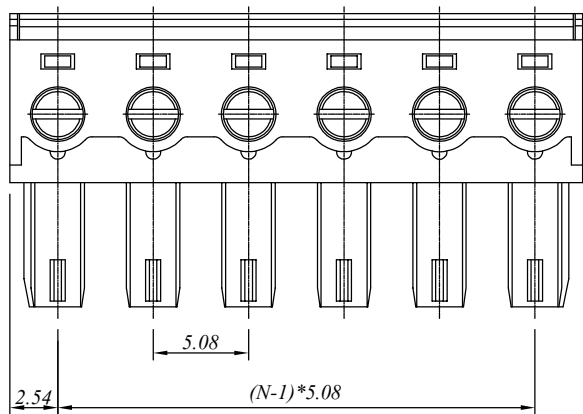
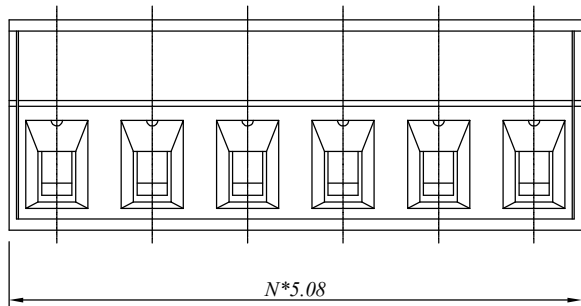

材质于电镀 / Material

塑件/Insulator body:

PA66, UL94V-0

方块/Contact(metal housing):

Brass ,Ni plated

螺丝/Terminal screw:

M2.0, Steel Zn plated

夹子/Clamp:

Phosphor bronze, Ni plated

电器性能 / Electrical

参考标准/Standard:

UL IEC

额定电压/Rated voltage:

300V 250V

额定电流/Rated current:

8A 10A

接触电阻/Contact resistance:

20m Ω (max)

绝缘电阻/Insulation resistance:

500M Ω /500V

耐电压/Withstanding voltage:

AC 2000V/1Min

使用线径/Wire range:

16-28AWG, 1.0mm²

机械性能 / Mechanical

扭矩/Torque:

0.2Nm(1.7Lb.in)

温度范围/Temperature range:

-40°C to +105°C

剥线长度/Steip length:

6-7mm

瞬间温度/Max soldering:

+250°C, for 5 Sec

尺寸 / Dimensions

间距/Pitch:

5.08mm

极数/Poles:

2-24P

N=Number of contacts

慈溪万海电子有限公司
CIXI WANHAI ELECTRONICS CO., LTD.

PART. NAME: 15EDGK-5.08-XXP

TITLE:

PART. NO.:

DWG NAME:

APPROVED BY

CHECKED BY

DESIGNED BY

DRAWN BY

CUSTOM NO.:

Tolerance

X ±0.50

X.X ±0.30

X.XX ±0.10

XX° ±1°



UNITS:mm

SCALE:1.9/1

REVISION:5