

SIGN	DATE	DESCRIPTION	APPROVER
△			
△			
△			

# P.C.B. LAYOUT

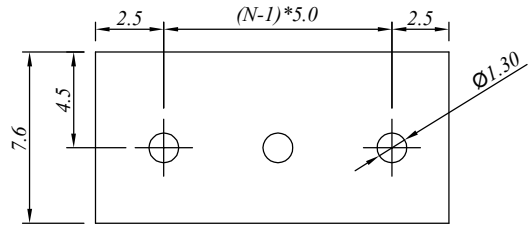
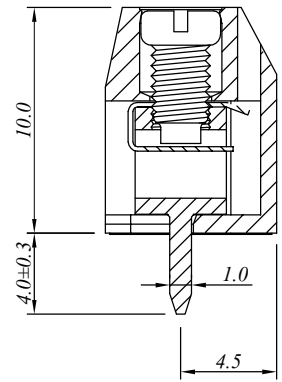
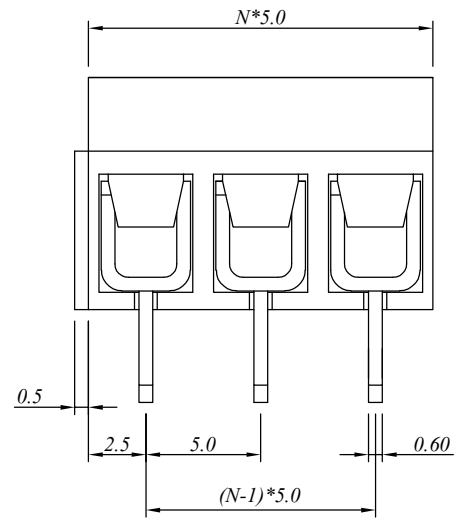
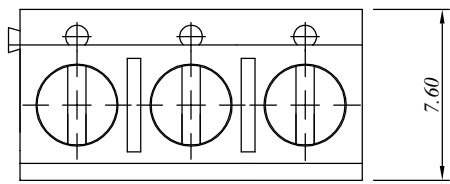

N=Number of contacts

## 材质于电镀/Material

塑件/Insulator body: PA66, UL94V-0  
 方针/Contact(metal housing): Brass, Tin plated  
 螺丝/Terminal screw: M2.5, Steel Zn plated  
 弹片/Wire guard: Stainless steel

## 电器性能/Electrical

参考标准/Standard: UL IEC  
 额定电压/Rated voltage: 250V 250V  
 额定电流/Rated current: 16A 17.5A  
 接触电阻/Contact resistance: 20mΩ (max)  
 绝缘电阻/Insulation resistance: 500MΩ /500V  
 耐电压/Withstanding voltage: AC 2000V/1Min  
 使用线径/Wire range: 14-26AWG, 1.5mm<sup>2</sup>

## 机械性能/Mechanical

扭矩/Torque: 0.4Nm(3.6Lb.in)  
 温度范围/Temperature range: -40°C to +120°C  
 剥线长度/Steip length: 6-7mm  
 瞬间温度/Max soldering: +250°C, for 5 Sec

## 尺寸/Dimensions

间距/Pitch: 5.0mm  
 极数/Poles: 2-24P

慈溪万海电子有限公司  
**CIXI WANHAI ELECTRONICS CO., LTD.**

PART. NAME: JM306-5.0-XXP				TITLE:	
PART. NO.:				DWG NAME:	
APPROVED BY	CHECKED BY	DESIGNED BY	DRAWN BY	CUSTOM NO.:	Tolerance x. ±0.50 x.x ±0.30 x.xx ±0.10 xx° ±1°
				UNITS: mm SCALE: 4/1 REVISION: B3	