

SIGN	DATE	DESCRIPTION	APPROVER
△			
△			
△			

P.C.B. LAYOUT

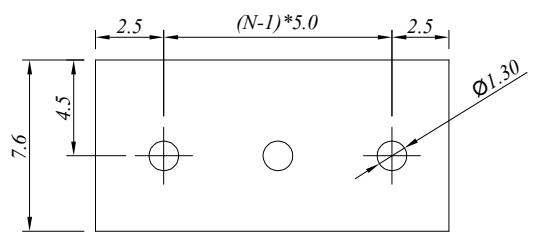
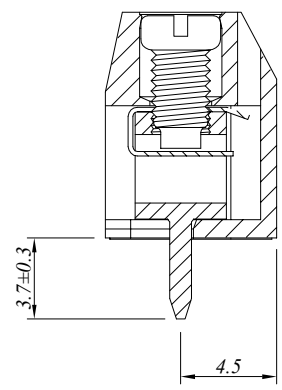
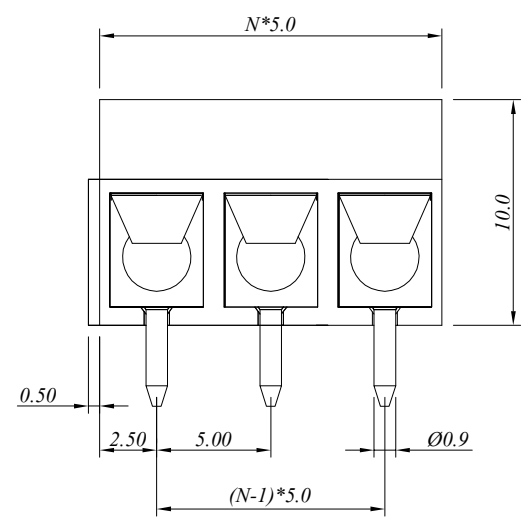
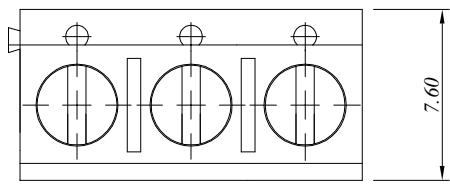

N=Number of contacts

材质于电镀/Material

塑件/Insulator body: PA66, UL94V-0
 方针/Contact(metal housing): Brass ,Tin planted
 螺丝/Terminal screw: M3, Steel Zn planted
 弹片/Wire guard: Stainless steel

电器性能/Electrical

参考标准/Standard: UL IEC
 额定电压/Rated voltage: 300V 250V
 额定电流/Rated current: 15A 17.5A
 接触电阻/Contact resistance: 20m Ω (max)
 绝缘电阻/Insulation resistance: 500M Ω /500V
 耐电压/Withstanding voltage: AC 2000V/1Min
 使用线径/Wire range: 14-26AWG, 1.5mm²

机械性能/Mechanical

扭矩/Torque: 0.5Nm(4.5Lb.in)
 温度范围/Temperature range: -40°C to +120°C
 剥线长度/Steip length: 5-6mm
 瞬间温度/Max soldering: +250°C, for 5 Sec

尺寸/Dimensions

间距/Pitch: 5.0mm
 极数/Poles: 2-24P

慈溪万海电子有限公司 CIXI WANHAI ELECTRONICS CO., LTD.

PART. NAME: JM301-5.0				TITLE:	
PART. NO.:				DWG NAME:	
APPROVED BY	CHECKED BY	DESIGNED BY	DRAWN BY	CUSTOM NO.:	Tolerance x. ±0.50 x.x ±0.30 x.xx ±0.10 xx° ±1°
				UNITS: mm	
				SCALE: 4/1	
				REVISION:B3	